



User Manual

LucidControl AO4

4 Channel Analog Output USB Module

1 Introduction

This document describes the functionality of the LucidControl AO4 USB module generating 4 analog voltages or currents controllable via Universal Serial Bus.

A basic description of the complete LucidControl product family can be found in the document *LucidControl User Manual*.

This document concentrates on the specific topics of the analog output module which is described here with all its details. In order to set up the module in a fast way please see the

LucidControl AO4 One Sheet Manual

which provides all information necessary to start working with the module out of the box without reading lots of documentation.

2 Hardware

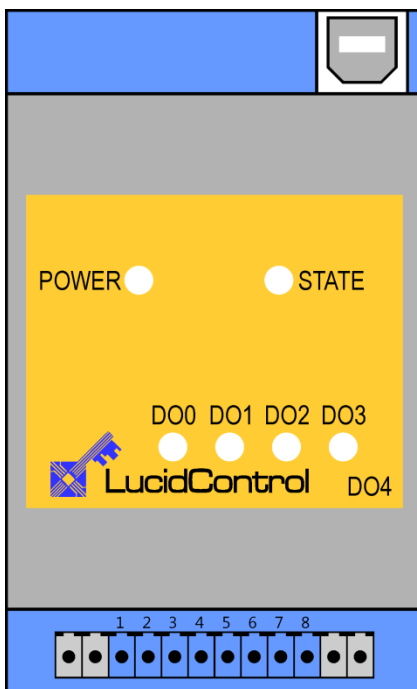

Fig. 1 Digital Output Module

Fig. 1 shows the sketch of the Analog Output AO4 module with 4 analog voltage or current outputs.

All LucidControl modules have two connectors, one USB connector and an IO-Connector which makes it easy to setup them.

While the upper USB connector is used for interconnection with the computer, the lower IO-Connector is used for inputs and outputs.

The IO Connector provides 8 terminals in total - two for each output.

The intended use of the analog output module is the generation of analog voltage and current signals. The module must only be used for the intended use.



For the analog output module it is explicitly stated that no potential of any external power source must be applied to any connector of the module. The modules must only be used within the specified conditions.

2.1 Configurations

LucidControl AO4 is available with the following output types:

Module Type	Type Number	Output Voltage Range	
		V _{Min}	V _{Max}
Positive Outputs	LCTR-AO4-5	0 V	5 V
	LCTR-AO4-10	0 V	10 V
	LCTR-AO4-24	0 V	24 V
Symmetrical Outputs	LCTR-AO4-12-S	-12 V	12 V

Tab. 1 Output Voltage Range

Module Type	Type Number	Output Voltage Range	
		I _{Min}	I _{Max}
Positive Outputs	LCTR-AO4-20M0	0 mA ¹⁾	20 mA
	LCTR-AO4-20M4	4 mA	20 mA

Tab. 2 Output Current Range

Note:

- 1) A minimum saturation current remains on the output. See I_{ChMin} in specification.

2.2 Interface and Interconnection

2.2.1 USB Connection

LucidControl USB modules are connected to the computer by using a standard USB cable which must not extend a length of 5 m. They are "bus powered" which means that the host computer supplies the module with power.

LucidControl AO4 module is rated with a maximum current of 250 mA.

Note:

Supplying USB devices with power is not critical using a desktop computer or notebooks but it must be considered that the total power of one USB port is limited to 500 mA.

Note:

Using an active USB-Hub with its own power supply allows the connection of additional devices in the case that the host is not able to supply them.

2.2.2 IO Connection

Fig. 2 shows the interconnection of the voltage output module in a typical application.

In this application the analog output voltages are sourcing LEDs.

The terminals 2, 4, 6 and 8 are internally connected to ground.

Fig. 2 Voltage Output Module Connection

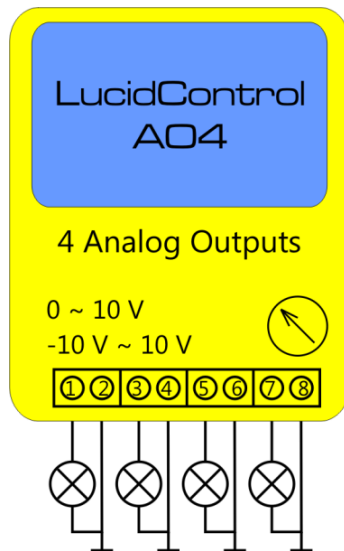
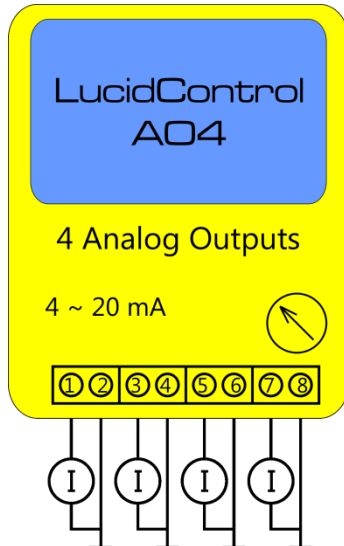

Fig. 3 shows the interconnection of the current output module.

The outputs are connected to current measurement devices.

The terminals 2, 4, 6 and 8 are internally connected to ground.

Fig. 3 Current Output Module Connection



The load current per channel must not exceed I_{ChMax} . The sum of all 4 output channels must not exceed $I_{TotalMax}$.

2.2.2.1 4 Voltage Outputs

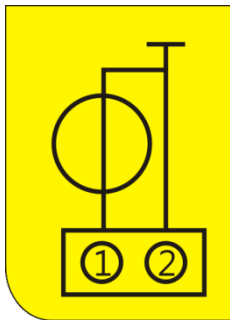

The voltage output module shown in Fig. 3 consists of 4 independent voltage sources as they are shown in Fig. 4.

The positive outputs are connected to the terminals 1, 3, 5 and 7 of the IO Connector. The remaining terminals 2, 4, 6, 8 are connected to ground.

Fig. 4 Voltage Source

2.2.2.2 2 Floating Voltage Outputs

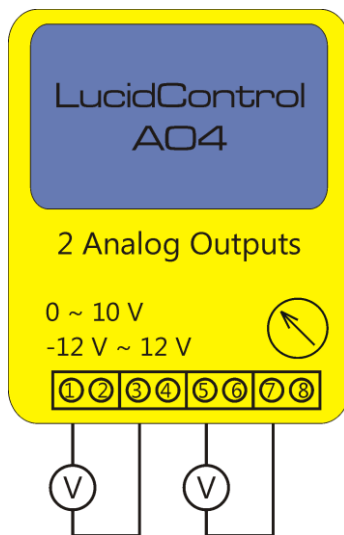

All 4 voltage outputs share a common ground. A floating output can be achieved by connecting the outputs as shown in Fig. 5. In the picture two of the 4 independent voltage sources are connected in series.

Voltage output modules providing positive and negative voltages e.g. LCTR-AO4-12-S are able to double their output voltage. By connecting this module as shown in Fig. 5 can create voltages in the range of -24V to +24V.

Fig. 5 Symmetrical Voltage Outputs

2.2.2.3 Current Outputs

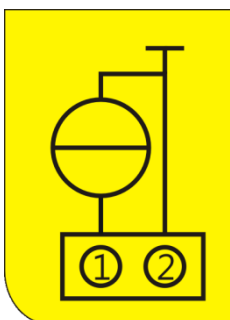

The current output module shown in Fig. 3 consists of 4 independent current sources as they are shown in Fig. 6.

The positive outputs are connected to the terminals 1, 3, 5 and 7 of the IO Connector. The remaining terminals 2, 4, 6, 8 are connected to ground.

Fig. 6 Current Source

2.3 Isolation of USB Interface (-ISO option)

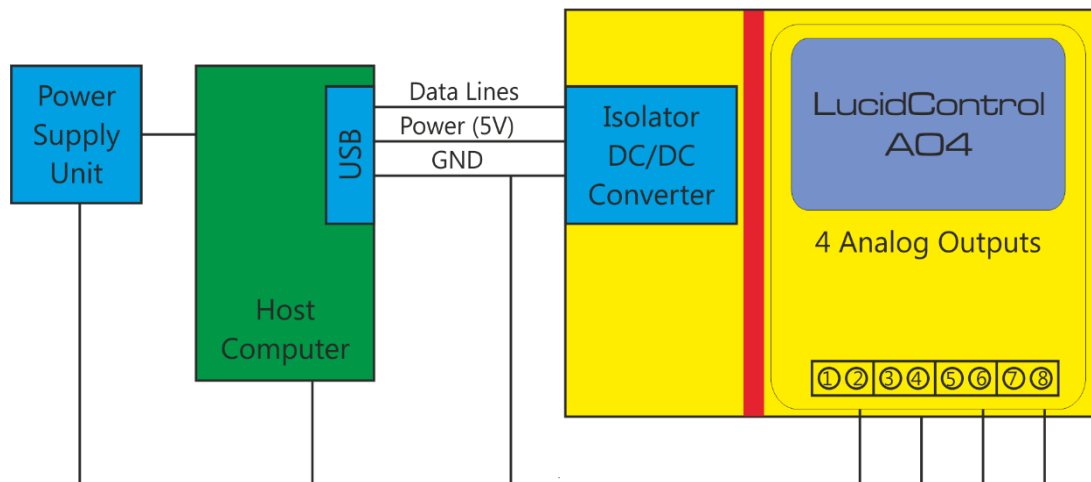

Fig. 7 AO4 Module with isolated USB Interface

AO4 module is optionally available with isolated USB interface (-ISO option).

Fig. 7 shows the AO4 module with isolated USB interface.

The isolation consists of a galvanic barrier (red area) that isolates the IO module entirely from the USB data lines and power supply lines. An isolated DC/DC converter separates the power supply.

The main purpose of the isolated LucidControl module is the separation of the IO module from the data processing equipment (e.g. the host computer). Non-Isolated IO modules are conductive connected to the USB port also sharing a common ground line.

Harsh or noisy environments (e.g. with disturbances or long cables) may cause measurement errors or malfunction of the data processing equipment or the IO module caused by ground loops. This can be solved by the isolation of the USB port.

Another aspect is the protection of the data processing equipment from overvoltage. If for example a voltage above the limits of the module is applied to the terminals this can damage the module and the data processing equipment also.

The isolation limits the possible damage to the IO module itself.

USB isolation can be an option if a higher protection level required or if LucidControl IO modules are operating in harsh environments.



Even when the isolation protects the data processing equipment from overvoltage damage it does not protect from voltages > 50V!

2.4 Setup of Hard- and Software

Setting up LucidControl hardware is extremely easy:

- 1 Ensure that no signal is applied to the IO Connector
- 2 Connect LucidControl via USB with the computer
- 3 Applies for Microsoft windows only: The system asks for an installation file. This is not a driver but only an information file (INF). The file can be downloaded from our website www.lucid-control.com/downloads
- 4 That's all. LucidControl switches the green power LED on and the module is ready for usage.

2.4.1 Windows

As mentioned the installation under Microsoft Windows requires the information file.

After finished installation the Windows Device Manager contains a new serial port (COM). The module can be accessed using this port.

Note:

Even if more than one module is connected to a computer Windows ensures that the same serial port number is assigned to the module(s) after restart.

2.4.2 Linux

Despite to Windows installation under Linux the module is usable immediately after connection without any additional steps. Linux installs /dev/ttyACM devices for any module connected to the computer.

Note:

By default Linux cannot ensure that the same /dev/ttyACM device is assigned to the same module on restart. But as long as only one module is connected to the computer it is ensured that it is accessible via /dev/ttyACM0.

This problem can be solved by the LucidIoCtrl command line tool which can create static devices always pointing to a specific module. Moreover the device can be given useful names e.g. dev/digitalIoKitchen.

2.4.3 Get command line LucidIoCtrl

LucidIoCtrl command line tool can be downloaded from our website:

www.lucid-control.com/downloads

This page provides the command line tool LucidIoCtrl for different architectures.

After downloading the program can be stored in a folder of choice.

Please see the section 3 of the general LucidControl User Manual for more information about this helpful tool.

2.4.4 Ready to Start

After the module was installed successfully (if it was necessary at all) the green Power LED is switched on signaling that the module is ready for use.

Since the module was preconfigured for standard output mode, it can be used without further configuration. The following examples demonstrate the functionality of the module by using the LucidIoCtrl command line tool.

The following examples demonstrate the functionality of the module by using the LucidIoCtrl command line tool.

Windows Examples:

For all examples it is assumed that the module is connected to COM1.

Set the values of all 4 voltage output channels. Value of CH0 = 5.000 V, CH1 = 2.500 V, CH2 = 1.250 V, CH3 = 0.625 V

```
LucidIoCtrl -dCOM1 -tV -c0,1,2,3 -w5.000,2.500,1.250,0.625 [ENTER]
```

Set the values of all 4 current output channels. Value of CH0 = 5.000 mA, CH1 = 2.500 mA, CH2 = 1.250 mA, CH3 = 0.625 mA

```
LucidIoCtrl -dCOM1 -tC -c0,1,2,3 -w5.000,2.500,1.250,0.625 [ENTER]
```

Linux Examples:

For all examples it is assumed that the module is connected to /dev/ttyACM0.

Set the values of all 4 output channels. Value of CH0 = 5.000 V, CH1 = 2.500 V, CH2 = 1.250 V, CH3 = 0.625 V

```
LucidIoCtrl -d/dev/ttyACM0 -tV -c0,1,2,3 -w5.000,2.500,1.250,0.625 [ENTER]
```

Set the values of all 4 current output channels. Value of CH0 = 5.000 mA, CH1 = 2.500 mA, CH2 = 1.250 mA, CH3 = 0.625 mA

```
LucidIoCtrl -d/dev/ttyACM0 -tC -c0,1,2,3 -w5.000,2.500,1.250,0.625 [ENTER]
```

3 Module Operation

The LucidControl AO4 Analog Output Module generates 4 independent output voltage or current signals.

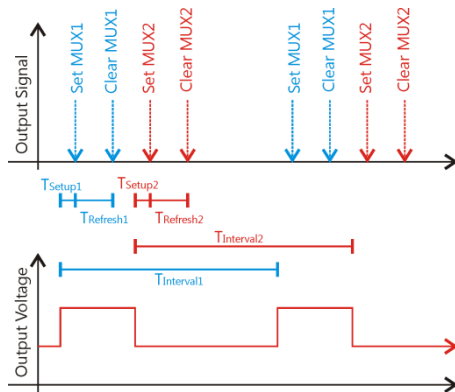

Fig. 8 Output Processing

The Hardware of the AO4 module consists of 2 independent DAC (Digital Analog Converter). By multiplexing each DAC, 4 output voltages or currents are created in total.

Fig. 8 illustrates the output processing in standard mode. Each of the two DAC is responsible for the generation of two analog output signals.

The processing of both DAC channels is operating in parallel the same way. For simplicity only the processing of one DAC is shown in Fig. 8.

The lower diagram in Fig. 8 shows the DAC output signals – a higher voltage for output 1, a lower voltage for output 2.

The upper diagram depicts the timing sequence of the output multiplexing and refreshing algorithm for each DAC.

After the DAC set the updated voltage of output 1 and T_{Setup} has passed the output multiplexer applies the signals to the output circuit. T_{Setup} is a guard time preventing to overwrite the stable voltage of the last refresh cycle.

The voltage is applied to the output circuit for the time $T_{Refresh}$. After refreshing has completed, the DAC generates the updated signals of output 2. Output 2 is processed the same way as output 1 was.

The refreshing algorithm repeats periodically after $T_{Interval}$ has passed.

Even if T_{Setup} , $T_{Refresh}$ and $T_{Interval}$ can be adjusted for each output channel independently, this should only be taken into account if it is necessary since changing these parameters may have unexpected consequences like skipped output channels or high voltage ripple. The relevant IO Configuration Parameters are *outAnSetupTime* (see 3.4.5), *outAnRefreshTime* (see 3.4.4) and *outAnRefreshInterval* (see 3.4.3).

At any time it is possible to restore the default values of changed parameters.

3.1 Operation Modes

3.1.1 Inactive Mode

Setting an output to inactive mode disables processing of the output and sets the output voltage to minimum value (e.g. 0 V).

Setting an output to Inactive Mode does not suspend the output processing and refreshing but forces the output voltage to minimum value.

3.1.2 Standard Mode

In standard mode the processing of the analog output is executed as described in section 3.

3.2 Offset Compensation

In some cases it is necessary to compensate an offset signal by adding a value to the output voltage or current.

The signed value of the IO Configuration Parameter *outAnOffset* (see 3.4.6) is added to the output signal and allows an offset correction.

3.3 Commands

Accessing inputs and outputs is a very common task which is mostly identical for all LucidControl modules. For this task output modules provide the commands *SetIo* for writing a single value and *SetIoGroup* for writing a group of values of the same type.

The command *GetIo* supports reading of the state of a single output value while *GetIoGroup* reads a group of output values of the same type.

For more comprehensive information covering reading and writing of inputs and outputs please see the sections 3.2.1.1, 3.2.1.2 and 4.3 of the general LucidControl manual.

The following sections describe in detail the commands which are supported by the AO4 module.

3.3.1 SetIo

This command sets the output signal of one output channel.

Command	SetIo	Access	Write
Opcode	0x40		
LucidIoControl Command Line Tool			
Call (-tV)	LucidIoCtrl -d[COMx] -c[Channel] -tV -w[Voltage] LucidIoCtrl -d[COMx] -c[Channel] -tC -w[Current]		

Note:

When using the LucidIoCtrl command line tool, the distinction between the SetIo and SetIoGroup commands is not necessary since LucidIoCtrl command line tool handles this automatically.

LucidIoCtrl Command Line Tool Example

Set output channel 0 to 2.540 V:

```
LucidIoCtrl -dCOM4 -c0 -tV -w2.540 [ENTER]
```

Set output channel 0 to 10 mA:

```
LucidIoCtrl -dCOM4 -c0 -tC -w10 [ENTER]
```

Request Frame

OPC	P1	P2	LEN	Data Field
0x40	Channel	Value Type	Length	Value

Value	Description												
Channel	Number of input or output channel (Range: 0 ~ 3)												
Value Type	Value Type Supported Value Types												
	<table border="1"> <thead> <tr> <th>Value Type</th> <th>Value Range</th> <th>Length</th> </tr> </thead> <tbody> <tr> <td>Signed Voltage Resolution 1 μV (0x1D)</td> <td>-100,000,000 μV ~ 100,000,000 μV (-100 V ~ 100 V)</td> <td>4 Bytes</td> </tr> <tr> <td>Signed Voltage Resolution 1 mV (0x1C)</td> <td>-30,000 mV ~ 30,000 mV (-30 V ~ 30 V)</td> <td>2 Bytes</td> </tr> <tr> <td>Signed Current Resolution 1nA (0x23)</td> <td>-1,000,000,000 nA ~ 1,000,000,000 nA (-1 A ~ 1A)</td> <td>4 Bytes</td> </tr> </tbody> </table>	Value Type	Value Range	Length	Signed Voltage Resolution 1 μ V (0x1D)	-100,000,000 μ V ~ 100,000,000 μ V (-100 V ~ 100 V)	4 Bytes	Signed Voltage Resolution 1 mV (0x1C)	-30,000 mV ~ 30,000 mV (-30 V ~ 30 V)	2 Bytes	Signed Current Resolution 1nA (0x23)	-1,000,000,000 nA ~ 1,000,000,000 nA (-1 A ~ 1A)	4 Bytes
Value Type	Value Range	Length											
Signed Voltage Resolution 1 μ V (0x1D)	-100,000,000 μ V ~ 100,000,000 μ V (-100 V ~ 100 V)	4 Bytes											
Signed Voltage Resolution 1 mV (0x1C)	-30,000 mV ~ 30,000 mV (-30 V ~ 30 V)	2 Bytes											
Signed Current Resolution 1nA (0x23)	-1,000,000,000 nA ~ 1,000,000,000 nA (-1 A ~ 1A)	4 Bytes											
Length	Length of the Values in the Data Field												
Value	Values accordingly to the Value Type												

Tab. 3 SetIo Request

Response Frame

Status	Length
Status	0

The command does not return any data. In the case of an error the command returns Execution Status Code documented in section 4.4 of the LucidControl User Manual.

3.3.2 SetIoGroup

This command sets the voltage or current of a group of output channels of the same Value Type.

Command	SetIoGroup	Access	Write
Opcode	0x42		
LucidIoControl Command Line Tool			
Call (-tV)	LucidIoCtrl -d[COMx] -c[Channels] -tV -w[Voltages] LucidIoCtrl -d[COMx] -c[Channels] -tC -w[Currents]		
	<u>Channels:</u> Comma separated list of channels e.g. -c0,2,3		
	<u>Values:</u> Comma separated list of voltages or currents to set e.g. -w1.25,2.5,7.5		

LucidIoCtrl Command Line Tool Example

Set output channel 0 to 1.25 V, output channel 2 to 2.50 V and output channel 3 to 7.50:

```
LucidIoCtrl -dCOM4 -c0,2,3 -tV -w1.25,2.5,7.5 [ENTER]
```

Set output channel 0 to 5 mA, output channel 2 to 15.5 mA and output channel 3 to 20:

```
LucidIoCtrl -dCOM4 -c0,2,3 -tC -w5,15.5,20 [ENTER]
```

Request Frame:

OPC	P1	P2	LEN	Data Field
0x40	Channel Mask	Value Type	Length	Value(s)

Value	Description															
Channel Mask	Channel Mask Specifies the output channels to access															
	<table border="1"> <thead> <tr> <th>Channel</th> <th>Bit Position</th> <th>Value</th> </tr> </thead> <tbody> <tr> <td>0</td> <td>0</td> <td>0x01</td> </tr> <tr> <td>1</td> <td>1</td> <td>0x02</td> </tr> <tr> <td>2</td> <td>2</td> <td>0x04</td> </tr> <tr> <td>3</td> <td>3</td> <td>0x08</td> </tr> </tbody> </table>	Channel	Bit Position	Value	0	0	0x01	1	1	0x02	2	2	0x04	3	3	0x08
	Channel	Bit Position	Value													
	0	0	0x01													
	1	1	0x02													
2	2	0x04														
3	3	0x08														
Values are bitwise or combined																
<u>Examples:</u> Accessing channel 0 and 3 Value = 0x01 OR 0x08 = 0x09 Accessing channel 1 and 2 Value = 0x02 OR 0x04 = 0x06																
Value Type	Value Type Supported Value Types															
	<table border="1"> <thead> <tr> <th>Value Type</th> <th>Value Range</th> <th>Length</th> </tr> </thead> <tbody> <tr> <td>Signed Voltage Resolution 1 μV (0x1D)</td> <td>-100,000,000 μV ~ 100,000,000 μV (-100 V ~ 100 V)</td> <td>4 Bytes</td> </tr> <tr> <td>Signed Voltage Resolution 1 mV (0x1C)</td> <td>-30,000 mV ~ 30,000 mV (-30 V ~ 30 V)</td> <td>2 Bytes</td> </tr> <tr> <td>Signed Current Resolution 1nA (0x23)</td> <td>-1,000,000,000 nA ~ 1,000,000,000 nA (-1 A ~ 1A)</td> <td>4 Bytes</td> </tr> </tbody> </table>	Value Type	Value Range	Length	Signed Voltage Resolution 1 μ V (0x1D)	-100,000,000 μ V ~ 100,000,000 μ V (-100 V ~ 100 V)	4 Bytes	Signed Voltage Resolution 1 mV (0x1C)	-30,000 mV ~ 30,000 mV (-30 V ~ 30 V)	2 Bytes	Signed Current Resolution 1nA (0x23)	-1,000,000,000 nA ~ 1,000,000,000 nA (-1 A ~ 1A)	4 Bytes			
	Value Type	Value Range	Length													
	Signed Voltage Resolution 1 μ V (0x1D)	-100,000,000 μ V ~ 100,000,000 μ V (-100 V ~ 100 V)	4 Bytes													
Signed Voltage Resolution 1 mV (0x1C)	-30,000 mV ~ 30,000 mV (-30 V ~ 30 V)	2 Bytes														
Signed Current Resolution 1nA (0x23)	-1,000,000,000 nA ~ 1,000,000,000 nA (-1 A ~ 1A)	4 Bytes														
Length	Length of the Values in the Data Field (One Value for each channel)															
Values	One or more values to set in ascending channel order															

Tab. 4 SetIoGroup Request

Response Frame

Status	Length
Status	0

The command does not return any data. In the case of an error the command returns Execution Status Code documented in section 4.4 of the LucidControl User Manual.

Example of SetIoGroup

The following request frame sets outputs 0 to 1.25 V and output 1 to 2.5 V.

Request Frame

OPC	P1	P2	LEN	Data Field							
0x42	0x03	0x1D	0x08	Byte							
				Value Output 0				Value Output 1			
				0	1	2	3	4	5	6	7
				0xD0	0x12	0x13	0x00	0xA0	0x25	0x26	0x00

Channel Mask for Param1: 0x01 OR 0x02 = 0x03

Output Values in Data Field are sorted: Channel 0, Channel 1

Response Frame:

Status	Length
0x00	0x00

3.3.3 GetIo

This command reads the voltage or current of the analog output.

Command	GetIo	Access	Read				
Opcode	0x46						
LucidIoControl Command Line Tool							
Call (-tL)	LucidIoCtrl -d[COMx] -c[Channel] -tV -r LucidIoCtrl -d[COMx] -c[Channel] -tC -r						
Return	CHn:VV <table border="1"> <tr> <td>n</td> <td>Output Channel</td> </tr> <tr> <td>VV</td> <td>Output Value</td> </tr> </table>			n	Output Channel	VV	Output Value
n	Output Channel						
VV	Output Value						

Note

When using the LucidIoCtrl command line tool the distinction between GetIo and GetIoGroup commands is not necessary since the program handles this automatically.

LucidIoCtrl Command Line Tool Example

Read voltage of output channel 0

```

    LucidIoCtrl -dCOM4 -c0 -tV -r [ENTER]
-> CH0:5.00000
    
```

Read current of output channel 0

```

    LucidIoCtrl -dCOM4 -c0 -tC -r [ENTER]
-> CH0:5.00000
    
```

Request Frame

OPC	P1	P2	LEN
0x46	Channel	Value Type	0

Value	Description												
Channel	Number of input or output channel (Range: 0 ~ 3)												
Value Type	Supported Value Types <table border="1"> <thead> <tr> <th>Value Type</th> <th>Value Range</th> <th>Length</th> </tr> </thead> <tbody> <tr> <td>Signed Voltage Resolution 1 μV (0x1D)</td> <td>-100,000,000 μV ~ 100,000,000 μV (-100 V ~ 100 V)</td> <td>4 Bytes</td> </tr> <tr> <td>Signed Voltage Resolution 1 mV (0x1C)</td> <td>-30,000 mV ~ 30,000 mV (-30 V ~ 30 V)</td> <td>2 Bytes</td> </tr> <tr> <td>Signed Current Resolution 1nA (0x23)</td> <td>-1,000,000,000 nA ~ 1,000,000,000 nA (-1 A ~ 1A)</td> <td>4 Bytes</td> </tr> </tbody> </table>	Value Type	Value Range	Length	Signed Voltage Resolution 1 μ V (0x1D)	-100,000,000 μ V ~ 100,000,000 μ V (-100 V ~ 100 V)	4 Bytes	Signed Voltage Resolution 1 mV (0x1C)	-30,000 mV ~ 30,000 mV (-30 V ~ 30 V)	2 Bytes	Signed Current Resolution 1nA (0x23)	-1,000,000,000 nA ~ 1,000,000,000 nA (-1 A ~ 1A)	4 Bytes
Value Type	Value Range	Length											
Signed Voltage Resolution 1 μ V (0x1D)	-100,000,000 μ V ~ 100,000,000 μ V (-100 V ~ 100 V)	4 Bytes											
Signed Voltage Resolution 1 mV (0x1C)	-30,000 mV ~ 30,000 mV (-30 V ~ 30 V)	2 Bytes											
Signed Current Resolution 1nA (0x23)	-1,000,000,000 nA ~ 1,000,000,000 nA (-1 A ~ 1A)	4 Bytes											

Tab. 5 GetIo Request

Response Frame:

In case of successful execution the command returns the value of the specified channel number.

Status	LEN	Data Field
Status	Length	Value

In the case of an error the command returns Execution Status Code documented in section 4.4 of the LucidControl User Manual.

3.3.4 GetIoGroup

This command reads the voltage or currents of a group of analog outputs of the same Value Type.

Command	GetIoGroup	Access	Read				
Opcode	0x48						
LucidIoControl Command Line Tool							
Call (-tV)	LucidIoCtrl -d[COMx] -c[Channels] -tV -r LucidIoCtrl -d[COMx] -c[Channels] -tC -r <u>Channels:</u> Comma separated list of channels e.g. -c0,1,3						
Return	List of values sorted from lower to higher channels CHn:VV <table border="1" style="margin-left: 20px;"> <tr> <td>n</td> <td>Input Channel</td> </tr> <tr> <td>VV</td> <td>Output Value</td> </tr> </table>			n	Input Channel	VV	Output Value
n	Input Channel						
VV	Output Value						

LucidIoCtrl Command Line Tool Example

Read output voltages of channel 0, 1 and 3:

```
LucidIoCtrl -dCOM4 -c0,1,3 -tV -r [ENTER]
-> CH0:1.25000 CH1:2.50000 CH3:5.00000
```

Read output currents of channel 0, 1 and 3:

```
LucidIoCtrl -dCOM4 -c0,1,3 -tC -r [ENTER]
-> CH0:1.25000 CH1:2.50000 CH3:5.00000
```

Request Frame

OPC	P1	P2	LEN
0x48	Channel Mask	Value Type	0

Value	Description															
Channel Mask	Channel Mask Specifies the output channels to access															
	<table border="1"> <thead> <tr> <th>Channel</th> <th>Bit Position</th> <th>Value</th> </tr> </thead> <tbody> <tr> <td>0</td> <td>0</td> <td>0x01</td> </tr> <tr> <td>1</td> <td>1</td> <td>0x02</td> </tr> <tr> <td>2</td> <td>2</td> <td>0x04</td> </tr> <tr> <td>3</td> <td>3</td> <td>0x08</td> </tr> </tbody> </table>	Channel	Bit Position	Value	0	0	0x01	1	1	0x02	2	2	0x04	3	3	0x08
	Channel	Bit Position	Value													
	0	0	0x01													
	1	1	0x02													
2	2	0x04														
3	3	0x08														
Values are bitwise or combined																
<u>Examples:</u> Accessing channel 0 and 3 Value = 0x01 OR 0x08 = 0x09 Accessing channel 1 and 2 Value = 0x02 OR 0x04 = 0x06																
Value Type	Supported Value Types															
	<table border="1"> <thead> <tr> <th>Value Type</th> <th>Value Range</th> <th>Length</th> </tr> </thead> <tbody> <tr> <td>Signed Voltage Resolution 1 μV (0x1D)</td> <td>-100,000,000 μV ~ 100,000,000 μV (-100 V ~ 100 V)</td> <td>4 Bytes</td> </tr> <tr> <td>Signed Voltage Resolution 1 mV (0x1C)</td> <td>-30,000 mV ~ 30,000 mV (-30 V ~ 30 V)</td> <td>2 Bytes</td> </tr> <tr> <td>Signed Current Resolution 1nA (0x23)</td> <td>-1,000,000,000 nA ~ 1,000,000,000 nA (-1 A ~ 1A)</td> <td>4 Bytes</td> </tr> </tbody> </table>	Value Type	Value Range	Length	Signed Voltage Resolution 1 μ V (0x1D)	-100,000,000 μ V ~ 100,000,000 μ V (-100 V ~ 100 V)	4 Bytes	Signed Voltage Resolution 1 mV (0x1C)	-30,000 mV ~ 30,000 mV (-30 V ~ 30 V)	2 Bytes	Signed Current Resolution 1nA (0x23)	-1,000,000,000 nA ~ 1,000,000,000 nA (-1 A ~ 1A)	4 Bytes			
	Value Type	Value Range	Length													
	Signed Voltage Resolution 1 μ V (0x1D)	-100,000,000 μ V ~ 100,000,000 μ V (-100 V ~ 100 V)	4 Bytes													
Signed Voltage Resolution 1 mV (0x1C)	-30,000 mV ~ 30,000 mV (-30 V ~ 30 V)	2 Bytes														
Signed Current Resolution 1nA (0x23)	-1,000,000,000 nA ~ 1,000,000,000 nA (-1 A ~ 1A)	4 Bytes														

Tab. 6 GetIoGroup Request

Response Frame:

In case of successful execution the command returns the read values of the channels specified in the Channel Mask.

Status	LEN	Data Field
Status	Length	Value(s)

In the case of an error the command returns Execution Status Code documented in section 4.4 of the LucidControl User Manual.

Example of GetIoGroup Request:

The following request frame reads outputs 0 and 1. It returns the output voltages as signed 4 byte result.

Opcode	P1	P2	Length
0x48	0x03	0x1D	0x00

Channel Mask (P1): 0x01 OR 0x02 = 0x03

Response Frame:

Output 0 = 1.25 V, output 1 = 2.50 V. Values in Data Field are in ascending channel order.

Header Field		Data Field							
Status	LEN	Bytes							
0x00	0x08	Value 0				Value 1			
		0	1	2	3	4	5	6	7
		0xD0	0x12	0x13	0x00	0xA0	0x25	0x25	0x00

3.4 Parameters

LucidControl IO modules can be configured by a set of System Configuration Parameters and IO Configuration Parameters.

The Parameters are accessible via the SetParam and GetParam command which are described in sections 4.3.5 and 4.3.6 of the LucidControl User Manual.

3.4.1 outAnValue

This IO Configuration Parameter represents the voltage or current value of the analog output.

Parameter	outAnValue	Access	Read / Write
Address	0x1000		
Values	Voltage in 1 μ V resolution		
Default Value	0	Parameter Type	4 bytes signed
LucidIoCtrl Command Line Tool			
Parameter Name	outAnValue	Parameter Values	-100,000,000 μ V ~ 100,000,000 μ V or -1,000,000 μ A ~ 1,000,000 μ A
Call (Set)	LucidIoCtrl -d[COMx] -c[Channel] -soutAnValue[=Value] {-p} {--default}		
Call (Get)	LucidIoCtrl -d[COMx] -c[Channel] -goutAnValue		

LucidIoCtrl Command Line Tool Example

Set output voltage of channel 0 to 5 V and make the setting persistent.

```
LucidIoCtrl -dCOM4 -c0 -soutAnValue=5000000 -p [ENTER]
```

Read output voltage of channel 0 (value is 5 V).

```
LucidIoCtrl -dCOM4 -c0 -goutAnValue [ENTER]
-> outAnValue=5000000
```

By using *outAnValue* an output value can be made persistent. In this case the stored voltage or current level is restored after a restart of the module.

Note:

For normal operation it is recommended to use the functions SetIo (see 0) and GetIo (3.3.3) in order to access the output channel value.

3.4.2 outAnMode

This IO Configuration Parameter configures the operation mode of the output.

Parameter	outAnMode	Access	Read / Write
Address	0x1100		
Values	Output Mode		
	Byte	Mode	
	0x00	inactive	
	0x01	standard	
Default Value	standard	Parameter Type	1 byte unsigned
LucidIoCtrl Command Line Tool			
Parameter Name	outAnMode	Parameter Values	inactive / standard
Call (Set)	LucidIoCtrl -d[COMx] -c[Channel] -soutAnMode[=Mode] {-p} {--default}		
Call (Get)	LucidIoCtrl -d[COMx] -c[Channel] -goutAnMode		

LucidIoCtrl Command Line Tool Example

Set operation mode of output channel 0 to Standard Mode and make the setting persistent.

```
LucidIoCtrl -dCOM4 -c0 -soutAnMode=standard -p [ENTER]
```

Read the operation mode of input channel 0.

```
LucidIoCtrl -dCOM4 -c0 -goutAnMode [ENTER]
-> outAnMode=standard
```

3.4.3 outAnRefreshInterval

This IO Configuration Parameter configures the output refresh interval $T_{Interval}$.

Parameter	outAnRefreshInterval	Access	Read / Write
Address	0x1111		
Values	$T_{Interval}$ in μ s (micro seconds)		

	$5 \text{ ms} \leq T_{\text{Interval}} \leq 100 \text{ ms}$		
Default Value	10 ms	Parameter Type	4 bytes unsigned
LucidIoCtrl Command Line Tool			
Parameter Name	outAnRefreshInterval	Parameter Values	Time [μs]
Call (Set)	LucidIoCtrl -d[COMx] -c[Channel] -soutAnRefreshInterval[=Time] {-p} {--default}		
Call (Get)	LucidIoCtrl -d[COMx] -c[Channel] -goutAnRefreshInterval		

LucidIoCtrl Command Line Tool Example

Set T_{Interval} of output channel 0 to 20 ms and make the setting persistent.

```
LucidIoCtrl -dCOM4 -c0 -soutAnRefreshInterval=20000 -p [ENTER]
```

Read T_{Interval} parameter of input channel 0.

```
LucidIoCtrl -dCOM4 -c0 -goutAnRefreshInterval [ENTER]
```

```
-> outAnRefreshInterval=20000
```

3.4.4 outAnRefreshTime

This IO Configuration Parameter configures the output refresh time T_{Refresh}

Parameter	outAnRefreshTime	Access	Read / Write
Address	0x1113		
Values	T_{Refresh} in μs (micro seconds) $0.1 \text{ ms} \leq T_{\text{Refresh}} \leq 10 \text{ ms}$		
Default Value	1 ms	Parameter Type	4 bytes unsigned
LucidIoCtrl Command Line Tool			
Parameter Name	outAnRefreshTime	Parameter Values	Time [μs]
Call (Set)	LucidIoCtrl -d[COMx] -c[Channel] -soutAnRefreshTime[=Value] {-p} {--default}		
Call (Get)	LucidIoCtrl -d[COMx] -c[Channel] -goutAnRefreshTime		

LucidIoCtrl Command Line Tool Example

Set T_{Refresh} of output channel 0 to 5 ms and make the setting persistent.

```
LucidIoCtrl -dCOM4 -c0 -soutAnRefreshTime=5000 -p [ENTER]
```

Read T_{Refresh} parameter of input channel 0

```
LucidIoCtrl -dCOM4 -c0 -goutAnRefreshTime [ENTER]
```

```
-> outAnRefreshTime=5000
```

3.4.5 outAnSetupTime

This IO Configuration Parameter configures the output refresh setup time T_{Setup} .

Parameter	outAnSetupTime	Access	Read / Write
Address	0x1112		
Values	T_{Setup} in μs (micro seconds) $0.1 \text{ ms} \leq T_{\text{Setup}} \leq 10 \text{ ms}$		
Default Value	1 ms	Parameter Type	4 bytes unsigned

LucidIoCtrl Command Line Tool			
Parameter Name	outAnSetupTime	Parameter Values	Time [μ s]
Call (Set)	LucidIoCtrl -d[COMx] -c[Channel] -soutAnSetupTime[=Value] {-p} {--default}		
Call (Get)	LucidIoCtrl -d[COMx] -c[Channel] -goutAnSetupTime		

LucidIoCtrl Command Line Tool Example

Set T_{Setup} of output channel 0 to 1.5 ms and make the setting persistent.

```
LucidIoCtrl -dCOM4 -c0 -soutAnSetupTime=1500 -p [ENTER]
```

Read T_{Setup} parameter of input channel 0

```
LucidIoCtrl -dCOM4 -c0 -goutAnSetupTime [ENTER]
```

```
-> outAnSetupTime=1500
```

3.4.6 outAnOffset

This IO Configuration Parameter configures the output offset compensation value which is described in section 3.2.

Parameter	outAnOffset	Access	Read / Write
Address	0x1120		
Values	Offset Compensation in 1 mV steps (-3 V ~ 3 V) Offset Compensation in 1 μ A steps (-3mA ~ 3mA)		
Default Value	0	Parameter Type	2 bytes signed
LucidIoCtrl Command Line Tool			
Parameter Name	outAnOffset	Parameter Values	Voltage [1 mV] Current [1 μ A]
Call (Set)	LucidIoCtrl -d[COMx] -c[Channel] -soutAnOffset[=Value] {-p} {--default}		
Call (Get)	LucidIoCtrl -d[COMx] -c[Channel] -goutAnOffset		

LucidIoCtrl Command Line Tool Example

Set output offset compensation value of output channel 0 to -5 mV and make the setting persistent.

```
LucidIoCtrl -dCOM4 -c0 -soutAnOffset=-5 -p [ENTER]
```

Read Offset Compensation value.

```
LucidIoCtrl -dCOM4 -c0 -goutAnOffset [ENTER]
```

```
-> outAnOffset=-5
```

4 Specification

Parameter		Condition	Value	
Outputs				
	No of Output Channels		4	
Output - Electrical Characteristics				
	Output Function	Digital to Analog Conversion		
	Resolution	12 bit		
	Base Accuracy	typ. $\pm 0.25\%$ of full scale range		
	Max. Output Current	AO4-24	$I_{TotalMax}$	40 mA
		Others		160 mA
Output – Electrical Characteristics of Current Outputs				
	Max. Output Voltage		U_{ChMax}	10 V
	Min. Output Current ⁴⁾	AO4-20M4	I_{ChMin}	4 mA
		AO4-20M0		typ. 0.25 mA
	Output Current Dependence ³⁾		R_L not 500 Ω	$\pm 0.5\%$
Output – Electrical Characteristics of Voltage Outputs				
	Max. Output Current per Channel	AO4-24	I_{ChMax}	10 mA ¹⁾
		Others		40 mA
	Min. Output Voltage ²⁾	AO4-24	U_{ChMin}	50 mV
		Others		See Note ²⁾
Output – Timing Characteristic				
	Value Update interval		T_{Update}	typ. 10 ms
	Setup Time for stable output		T_{Stable}	typ. 1 ms
	DAC Conversion Time		T_{Conv}	typ. 1 ms
Module – Communication				
	USB		2.0 Full Speed CDC Profil	
Module – Electrical Characteristics				
	Power Supply	USB Bus Powered with +5V No additional Power Supply needed.		
	Maximum Rated Supply Current	250 mA		
Module – Environment				
	Temperature	Storage	$-20\text{ }^{\circ}\text{C} \dots +70\text{ }^{\circ}\text{C}$	
		Operation	$0\text{ }^{\circ}\text{C} \dots +55\text{ }^{\circ}\text{C}$	
	Humidity	< 85 % RH, non-condensing		
Module – Housing				
	Dimensions L x W x H	90 x 54 x 62 mm		
	Weight (in total)	120 g		
	Assembly	Rail-Mount (EN 50022, TS35)		

	Protection Class (DIN 40050)	IP20
Module - Indicators		
	<ul style="list-style-type: none"> • Operation and Error Indicator • Communication Indicator 	
Software		
	Supported Operating Systems	Windows® XP, Windows® Vista, Windows® 7, Ubuntu, Debian, Raspbian
	Application Programming Interface (API)	Console / Terminal Application, Java and Python

Notes:

- 1) For currents > 2 mA an additional tolerance of max. 50 mV must be considered.
- 2) If not further specified, the modules are able to drive the minimum output value within the specified tolerances.
The minimum value is 0V for non –S voltage modules.
- 3) Outputs are calibrated to a base accuracy with 500Ω output resistors. For output resistances other than 500Ω, the Output Current Dependence applies.
- 4) For AO4-20M0, a minimum saturation current must be considered.

5 Order Information and Accessories

General type number format

LCTR-AO4-Range(-ISO)

Order Code	Product
LCTR-AO4-05	LucidControl Analog Output USB Module with 4 channels 0 ~ 5 V
LCTR-AO4-10	LucidControl Analog Output USB Module with 4 channels 0 ~ 10 V
LCTR-AO4-12-S	LucidControl Analog Output USB Module with 4 channels ± 12 V
LCTR-AO4-24	LucidControl Analog Output USB Module with 4 channels 0 ~ 24 V
LCTR-AO4-20M0	LucidControl Analog Output USB Module with 4 channels 0 ~ 20 mA
LCTR-AO4-20M4	LucidControl Analog Input USB Module with 4 channels 4 ~ 20 mA.

Order Code (ISO)	Product
-ISO	With galvanic isolation of USB Interface

The following accessories are available:

Order Code	Product
64.200.0005	Plug-In Terminal 8-way 1,5 mm ² wire

6 Document Revision

Date	Rev.	
2019/09/16	1.4	• Added documentation of USB Isolation

deciphe it GmbH
Schäferstr. 5
87600 Kaufbeuren / Germany
www.lucid-control.com

